

Nexi-4-Dxxxxx

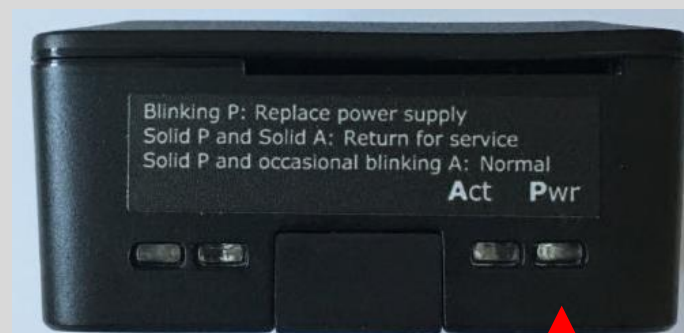

First, we will check the power.

Locate the Power Light (Pwr) on the side.

Power Light should be solid RED.

Is the Power Light solid RED?

If no Power Light, please plug in power.

If the Power Light is blinking, request and replace with a compatible power supply. DO NOT use any USB power supply. Many USB power supplies cannot provide enough power to the Nexi.

Make sure the power cord is clipped by the cord clip.

Nexi-4-Dxxxxx

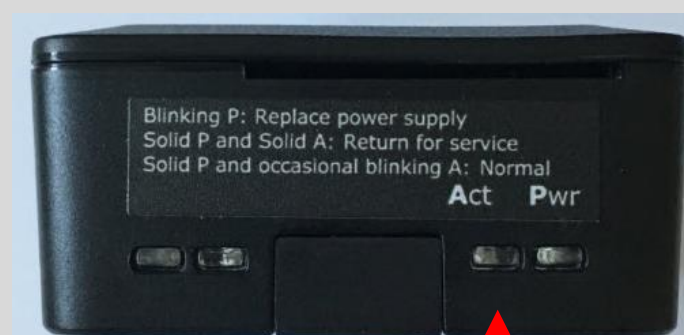

Next, we will check if the Nexi is running normally.

Locate the Activity Light (Act) on the side.

A blinking Activity Light is normal. The color is green. The blinking is sporadic.

Is the Activity Light blinking?

If Activity Light is off for more than 1 minute or it is constantly on for more than 1 minute, then there is an internal problem.

Please contact Neximatic for support.

Nexi-4-Dxxxxx



Next, we will check the networking (Ethernet).

If using Ethernet networking, check the lights on the Ethernet port on the side of the Nexi.

A light should be solid, and the other light should be blinking sporadically.

Are the lights on the Ethernet ok?

If the lights are off, check the following:

- Is the Ethernet cable connected?
- Is the wall Ethernet jet activated?

If static IP is used in the facility, the lights can be on but the Nexi still cannot use the network.

Please ask IT to ping this Nexi. IT would need to know the Nexi's hostname, which is the Nexi Name on the label.

If IT cannot ping this Nexi, the Nexi cannot access the network. Please contact Neximatic with local IT contact information.

Is there any recent change on the network?

If there is, please contact Neximatic with local IT contact information.

Nexi-4-Dxxxxx



Nexi, we will check the networking (WIFI).

Nexi-4 has an internal WIFI.

Ask IT if it can ping this Nexi. IT would need to know the Nexi's hostname, which is the Nexi Name on the label.

Can IT ping this Nexi?

If IT cannot ping this Nexi, the Nexi cannot access the network. Please contact Neximatic with local IT contact information.

Is there any recent change on the network (SSID, Password and etc)?

If there is, please contact Neximatic with local IT contact information.

Nexi-4-Dxxxxx

Medical Devices in the Room				
	Medical Device #1	Medical Device #2	Medical Device #3	Medical Device #4
Make	Mindray	Datex Ohmeda		
Model	Passport V	Aespire		
Interface used	SP1	Serial Port		
Configuration	Configuration			



Next, we will check the medical devices and any settings.

Go to Extended View.

Go to Medical Devices and Cables.

There is the information of the medical devices in this room

The Nexi is configured specifically for the medical devices.

Are the medical devices on that page correct?

If no, take pictures of the medical devices showing the Make/Model and then contact Neximatic for reconfiguration.

If a medical device requires any configuration, there will be a "Configuration" in the table.

Is the configuration set on the medical devices?

If no, follow the instruction in "Configuration" to set the medical device.

Nexi-4-Dxxxxx

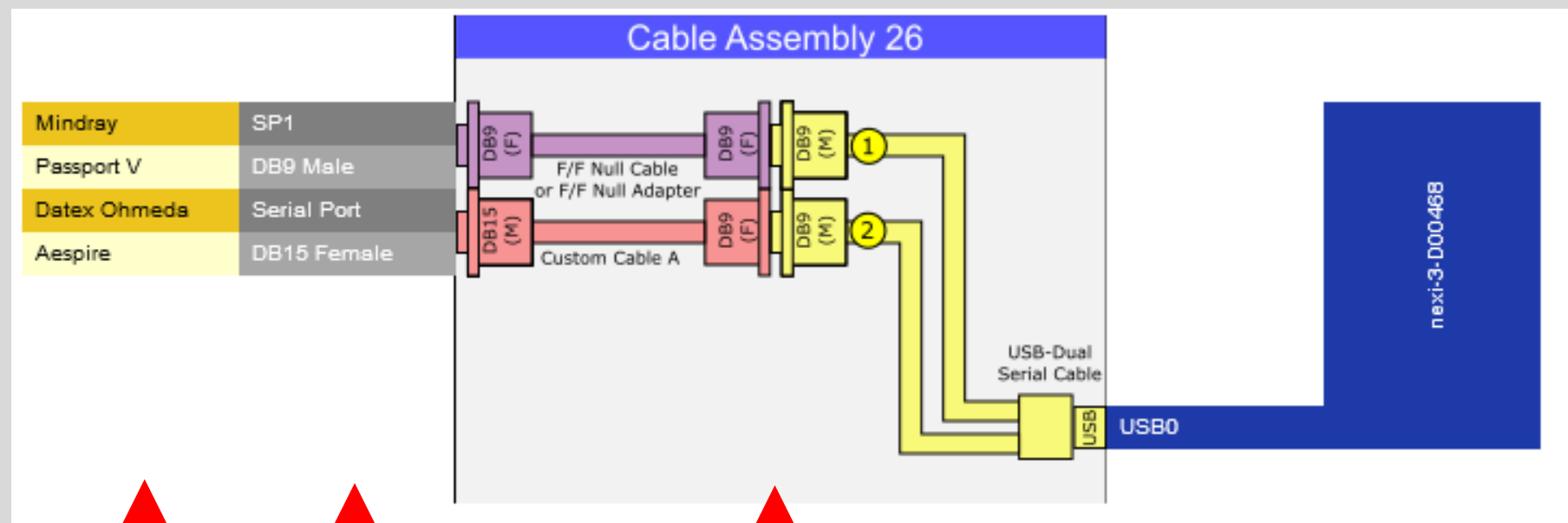

Next, we will check the cabling.

Go to Extended View.

Go to Medical Devices and Cables.

There is information of the cable assembly and how to connect the cable assembly.

Is the cable assembly connected to the correct ports of the medical devices?

If not, follow the diagram and connect the cable assembly correctly.

Nexi-4-Dxxxxx

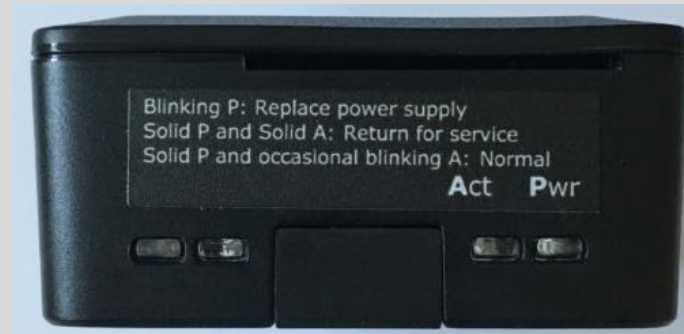

If there is still problem, please contact Neximatic for support.